



KEPNER

PRODUCTS COMPANY

Kep-O-Lok® Dual Lock Valves

Kep-O-Lok® 2800 series Dual Lock Valves have the Zero Leakage *Flexible Seal Seat™* locking the valve in both directions and is primarily used for cylinder holding. The valve free flows from valve port to cylinder port on the selected side, while at the same time piloting open the valve module on the other side to allow reverse flow. When the pressure input is removed, both valve modules close and lock against movement in either direction by preventing reverse fluid flow in either leg. Piloting is completely internal, and the close fitting pilot piston with pressure balancing grooves assures long life and virtually zero pilot losses.

Pipe threads are NPTF (Dryseal) female. SAE ports are internal straight thread O-ring boss. Conforms to MS 16142 (SHIPS)

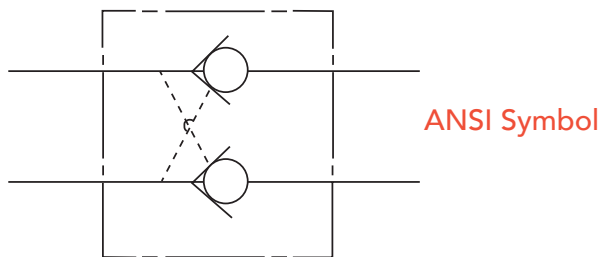

Typical Application

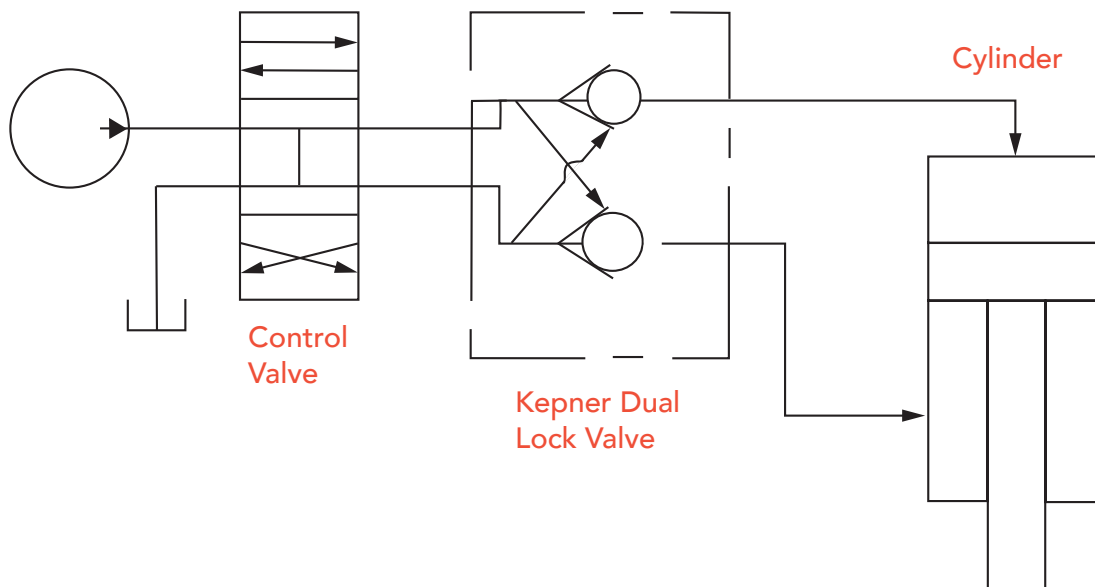

The cylinder piston is locked in place in both directions by the Kep-O-Lok® Dual Lock Valve as long as the control valve is centered. When the control valve is shifted to either side, oil pressure on the driving side internally pilots open the other valve module, allowing the piston to move as desired.

Kep-O-Lok® Dual Lock Valves are used with double-acting cylinders for position locking and for holding against linerupture or control valve leakage.

Consult Factory or Distributor for more help. Customer/user is solely responsible to select products suitable for their specific application requirements and to ensure proper installation, operation and maintenance of these products. Improper selection or use of products can cause personal injury or property damage. All sales are subject to Kepner Products Company Standard Terms and Conditions of Sale. Designs are subject to change without notice.